



Plastic-Free Packaging Design Guide

[g.co/Hardware/PackagingGuide](https://www.google.com/Hardware/PackagingGuide)

Edition 2.0
August 2024

What's inside?

Practical guidance and material insights for packaging and sustainability professionals.

Google

Table of contents

Foreword →

The challenge →

Why a new design →

Our new paper solution →

Replacing plastic components →

Coating solutions

Shrink wrap removal

Closure mechanisms

Paper tapes

Hang tabs

Protective product wraps

Inbox trays

Structural design →

The power of collaboration →

Glossary →

Plastic-free materials library →

Acknowledgments →

Resources →





Foreword

At Google, our mission is to organize the world's information and make it universally accessible and useful. We believe in the power of knowledge and are committed to sharing it in ways that positively impact people and the planet.

0.1 Challenges

Many companies have designed and engineered sustainable solutions for their products and services with impressive results. We think it's imperative that all companies do this. We also recognize that the challenges in building a more sustainable future are numerous and difficult. If all companies have to solve similar problems independently, then our collective progress will be slower.

0.2 Sharing knowledge

That's why we believe innovation in sustainability should be a collaborative endeavor, not a competitive one. In that spirit, we're sharing more than simply what we've achieved, but also how we achieved it. We've participated in many industry collaborations, but we're taking it one step further by openly publishing what we've learned for others to use, starting with our product packaging work. We aim to enable organizations on their own sustainability journeys and hope other companies will be inspired to share their insights, amplify their impact, and ultimately bring about the change we collectively need.



0.3 Our journey

Product packaging traditionally relies heavily on mixed materials, particularly those incorporating plastic. This poses a challenge for recycling and creates a significant waste stream, especially if it isn't accepted in recycling facilities.

This guide documents our journey to eliminate plastics and transition our packaging to predominantly fiber-based materials for all Google consumer electronics products. We hope this guide serves as a resource for others aiming to reduce their reliance on mixed material formats and adopt fiber-based solutions.

Through extensive material exploration, design optimization, and rigorous testing, we've identified viable alternatives to plastic that address key packaging elements. This guide offers practical guidance and material insights for product designers, packaging engineers, and sustainability leaders across many industries.

By sharing our learnings and collaborating with others, we hope to accelerate the transition to more sustainable packaging in a way that aligns innovation with environmental responsibility.

Meet the Google team

Design guide authors and contributors

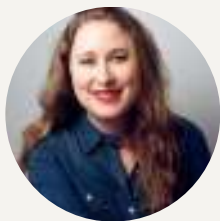

Julie Vree
Lead Writer



James Chao
Packaging
Production Manager



Amy Heck
Packaging Graphic
Designer



Emma Ghiselli
Packaging Graphic
Designer



David Bourne
Lead for Environmental
Strategy



Charlie Hutchinson
Structural Packaging
Design Innovation Lead



**Yang Xiang
PhD**
Packaging Materials
Engineer



Cole Hermann
Structural Packaging
Design Innovation Lead



Rob Cook
Packaging Design
Engineer Lead

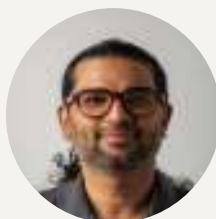

Abhinav Jha
Global Supply
Chain Manager



Francesca Delle Cese
Packaging Design
Engineer Manager



Miguel Arevalo
Packaging
Sustainability Lead



Section 1.0

The challenge of plastic in packaging

Confronting the ubiquity of plastic →

Our commitment →

Google's guiding principles →

Key materials in packaging →

Fiber – an emerging solution →

Why a new design →

Our new paper solution →

Confronting the ubiquity of plastic

Plastic isn't an inherently unsustainable material and has actually revolutionized the packaging industry.

Its barrier properties extend product shelf life, especially for perishable products like food. Its low weight reduces transportation costs and carbon emissions compared to heavier materials like glass. Plastic's versatility has allowed for a wide variety of applications in packaging, leading to a multitude of mixed material packaging formats in the packaging industry.

However, its ubiquity in packaging, particularly complex packaging, has created a high volume of mixed material waste that is difficult to recycle.¹ Consumer confusion around packaging recyclability is widespread and often results in improper disposal. Large volumes of plastic packaging often end up in landfills, waterways, and oceans harming ecosystems and wildlife as it slowly degrades into microplastics. It's a significant threat to the environment and ultimately our health. The plastic pollution crisis demands a fundamental shift in how we design, produce, use, and dispose of plastic. **It's a major challenge, but one that can be addressed.**

¹[The world's plastic pollution crisis, explained](#)
National Geographic, 2024





Our commitment

Organizations across all sectors are increasingly seeking ways to reduce their packaging waste footprint and so are consumers.

“Avoiding products which have a lot of packaging”² is the number one action people worldwide are taking out of concern for the environment. We hope this guide serves as a practical tool to help organizations make faster decisions to design more recyclable packaging solutions. It offers actionable tips, design insights, and examples for product designers, packaging engineers, and sustainability practitioners committed to minimizing plastic waste and maximizing fiber-based packaging recyclability.



Google recognizes the urgent need for packaging solutions that are more easily recycled. For our consumer electronics packaging, we’ve made a strategic shift away from plastics used in mixed-material formats. These formats complicate recycling efforts for consumers and material recovery facilities alike. For the consumer, deciding which packaging parts can be recycled and separating them is confusing and detracts from an otherwise delightful product unboxing experience. In October 2020 we made a commitment that **by 2025, all of our consumer electronics packaging will be 100% plastic-free.**

In our efforts to remove plastics, we’ve adopted the ISO 472³ definition of plastics: “*a material which contains as an essential ingredient a high polymer and which, at some stage in its processing into finished products, can be shaped by flow.*” This definition excludes materials like adhesives and inks.⁴ Even for these however, we conduct repulpability and recyclability testing to ensure that Google packaging materials can be widely recycled.

² [Earth Day 2022](#)
National Geographic, 2024

³ Per [ISO 0472-2013](#)
Plastic, noun. Material which contains as an essential ingredient a high polymer and which, at some stage in its processing into finished products, can be shaped by flow.

⁴ Note 1 to entry: *Elastomeric materials, which are also shaped by flow, are not considered to be plastics.*

Our guiding principles

These are fundamental to our approach.
We strive to create packaging that:

Prioritizes recyclability

Materials must be widely compatible with existing and future recycling streams.

Minimizes waste

Optimizing packaging size and weight minimizes the overall material footprint.

Maximizes accessibility

Designed with everyone in mind, features like holes, lifts, and tabs promote intuitive component removal. [Learn more about our research in accessible packaging design.](#)

Protects products

Sustainable packaging cannot compromise a product's integrity. Replacing damaged products carries a significant environmental impact.

Embraces innovation

Creating new solutions demands constant exploration and collaboration.



Key materials in the world of packaging

Plastics

PP lamination

A plastic film laminated to paperboard, enhancing tensile strength, abrasion resistance, and moisture protection. It is difficult to separate in recycling processes.



Shrink wrap

A versatile film used to bundle and protect packaging and create tamper evidence. Its low material value for recycling and tendency to contaminate recycling streams often leads to landfill disposal.



Plastic wraps for products

While offering product protection, traditional plastic films often lack economically viable recycling options and end up in landfills.



Plastic alternatives

Molded fiber

A renewable and recyclable alternative to plastic for inbox trays, engineered with cushioning properties for superior product protection during transit and handling.

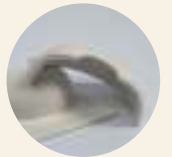

Greyboard

A robust material made from recycled content, offering structural rigidity and impact resistance to protect products during shipping and handling while maintaining a premium appearance.



High bulk bristol board

A lightweight and smooth board that is challenging to fold or bend. It makes for a great option to provide thickness or rigidity in a stack up while being smooth and relatively dust free.



Fiber

An emerging solution

The shift toward fiber-based packaging is gaining momentum.

Materials like paper and cardboard offer a compelling alternative to conventional plastics; they are renewable but can also be made from recycled content. They break down easily and integrate into the vast majority of existing consumer recycling systems.

While this transition presents opportunities, it also introduces challenges. Fiber-based solutions must meet the functional requirements for product packaging, particularly the protective properties that previously made plastic so popular. This necessitates new designs, materials, production methods, and supply chain adaptations.



Above: A fiber-based unglued packaging set



Why a new design?

We continue to push ourselves, and the boundaries of what's possible in packaging, in order to create a delightful and uniquely Google experience that meets our sustainability and accessibility goals.

100% plastic-free packaging is a significant step toward greater recyclability. However, consumer perception and recycling center screening also have a major impact on recycling outcomes for packaging materials. Some fiber-based solutions resemble plastic due to their sophisticated construction and are sometimes mistakenly sent to landfill. Our internal studies show that consumers recognize the visually speckled texture of our new materials as recyclable and are more likely to recycle it. Our new materials are also uncoated and are less likely to be seen as plastic in recycling centers.

Our new custom paper also reduces our transportation carbon footprint and has increased recycled content without compromising performance. We also prioritized accessibility for individuals with visual and dexterity impairments. Through extensive research and rigorous testing, we enhanced usability throughout the entire design process.

We're proud of the progress we've made, but we're not done yet. There's always room for improvement. Google remains committed to creating even better solutions that promote sustainability and empower all individuals.

Our new paper solution

Optimizing for weight and recyclability

Plastic traditionally offers valuable weight advantages, but is a challenging waste stream to recycle. For our packaging, we're leveraging the ubiquity of paper recycling and focusing on fiber-based solutions instead.

But lighter materials are preferred, and when we couldn't quite find a paper to match our protective quality needs that also minimized weight, we made one.



Collaborating for innovation

Together with Veritiv and Shandong Kaili Specialty Paper Company, we created a custom paper that raised the bar on several key requirements. Ultimately, our collaboration pushed the limits of what paper could do.

We specifically designed for tensile energy absorption (TEA) and stretchability. We defined Critical to Quality (CTQ) parameters for cosmetic performance, functional packaging performance, stretchability, surface strength, bending moment, and folding endurance. After multiple iterations, we created a custom formulation with an optimal fiber blend ratio and pulp refining parameters that met our CTQ targets for both cosmetic and functional packaging performance and successfully scaled up to mass production of our product portfolio.

Our new paper recipe is three times stronger and 70% more stretchable than our previous paper. It enabled us to use less material and create a lighter, more efficient packaging solution without sacrificing product protection. The lower packaging weight reduces the carbon footprint of transportation compared to our previous design.

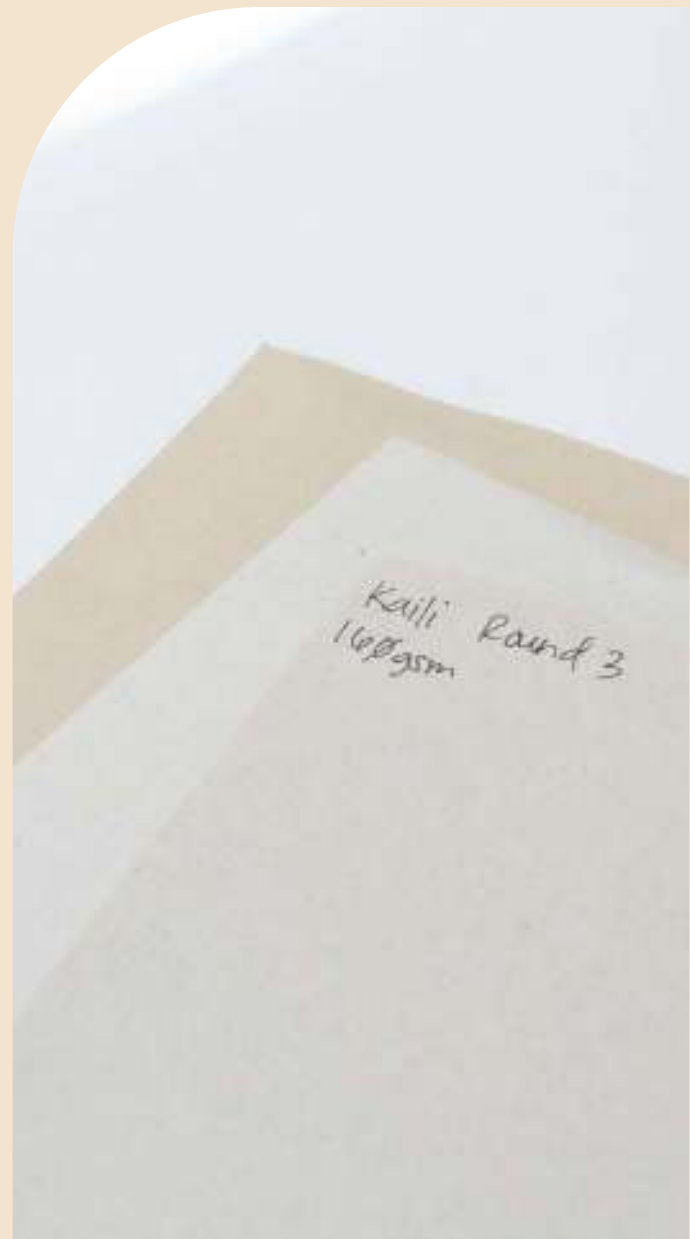



A new, versatile paper for everyone

We've chosen to make this custom paper available to all through our supplier. We hope it gives others a starting point for their own unique designs and accelerates the transition towards more sustainable packaging solutions.

Key insights ¹

The development time for new paper grades can vary significantly depending on the specific requirements and complexity of the paper. However, our team was able to develop our custom paper more efficiently than is typical for similar grades. This was achieved by:

- 1. Clearly defining CTQ and the targets based on our specific packaging applications.** This focused approach ensured that development efforts were aligned with our practical needs.
- 2. Providing complementary technical expertise to support the development process.** Using the insights provided through research combined with our team's skill sets and knowledge, we were able to optimize the formulation (fiber blend ratio) and the process in its entirety.
- 3. Partnering with a collaborative paper mill**

Our approach to overcoming challenges in new product development can serve as a valuable model for others seeking to create custom paper solutions. By setting clear goals, leveraging technical expertise, and partnering with collaborative suppliers, it's possible to expedite the development process and bring innovative paper products to market more efficiently.





Key insights ²

Our custom paper has several key elements that contribute to its sustainability profile:

- **18% recycled content.** A significant increase compared to our previous papers, demonstrating our commitment to utilizing recycled materials.
- **Enhanced tensile strength.** Despite the recycled content, this paper is about three times stronger in TEA, and about 70% more stretchable in machine direction (MD) than our previous paper at the same basis weight – this means we can use less material and create lighter packaging.
- **Uncoated for recyclability.** The uncoated nature of this paper maximizes fiber recovery during recycling and reduces the chance it will be mistaken for plastic and rejected during recycling.
- **FSC mix certification.** This certification ensures responsible sourcing of all paper fibers, including recycled content, FSC-certified suppliers, and reclaimed industrial residues.

Section 2.0

Replacing plastic components



[Coating solutions →](#)

[Shrink wrap removal →](#)

[Closure mechanisms →](#)

[Paper tapes →](#)

[Hang tabs →](#)

[Protective product wraps →](#)

[Inbox trays →](#)



Let's get started

We shared insights into the challenges, considerations, and innovative breakthroughs that pave the way for plastic-free packaging in the consumer electronics sector.

Transitioning to plastic-free packaging, and moving away from mixed material packaging formats, demands a rethinking of traditional components. Achieving the necessary product protection, accessibility, aesthetic appeal, and responsible disposal—all while managing costs—required expansive material exploration and testing.

Google is committed to this transformation, actively seeking sustainable solutions without sacrificing performance.

What we'll address

Let's dive into the complexities of replacing several common plastic components within our packaging.

For each component, we'll share an overview of our fiber-based solution, the performance testing conducted, and the results that validated our choices.

Coating solutions →

Alternatives to plastic laminations that provide protection and visual appeal.



Shrink wrap removal →

Strategies to effectively safeguard retail box graphics during shipping without plastic shrink wrap.



Closure mechanisms →

A system that ensures tamper-evident security and offers accessibility features.

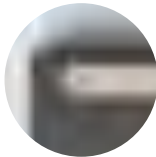

Paper tapes →

Assembly solutions that maintain structural integrity without plastic tapes.



Hang tabs →

Balancing strength with user-friendly design for product display.



Protective product wraps →

Materials that protect sensitive product surfaces and are compatible with recycling processes.

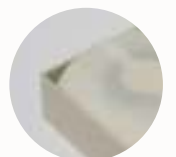

Inbox trays →

The shift to molded fiber trays from thermoformed plastic and the design optimizations required.





Shown:
Pixel 6 Pro packaging,
Fall 2021

Coating solutions

Coated and uncoated polypropylene (PP) films are commonly used in packaging.

Polypropylene is popular because of its protective qualities. However, when laminated to paper-based packaging, it creates significant challenges for recycling.

Challenge

* * * * *

“The quest for a recyclable coating was a balancing act. We needed to maintain the protective qualities of PP film while ensuring it wouldn’t disrupt the paper recycling process. It was a challenge, but one that pushed us to innovate.”

- Francesca

Packaging Design
Engineer Manager



Coating solutions



Lamination is a process that bonds multiple materials to form a stronger, more functional composite. In older Google packaging designs, a water-based adhesive was used to bind PP film to printed paper.

PP lamination has several advantages:

- Structural strength reinforces the paper, providing additional tensile strength to prevent tears and damage
- Scuffing / scratch resistance
- Moisture protection
- Visual appeal with a glossy or matte finish



Above: Plastic film removed / separated in a mill's hydropuller (repulping) system.

Unfortunately, PP laminated packaging disrupts paper recycling streams. During the pulping process, the plastic film does not break down like paper fibers. Instead, it must be screened out, ultimately contributing to landfill waste and reducing recycling yields. Large pieces of PP film float to the top of each recycling batch while small pieces are continuously strained out by size with a pressured screen and by density with cyclone cleaning.

Depending on the size and the collection system, the remains may not be recycled and could be landfilled. Replacing plastic laminations with coatings that are compatible with paper recycling is crucial to this goal. However, we recognize that even with coatings, maximizing fiber yield during recycling is essential.

Coating solutions



Upper left: Waring blender
 Upper right: British disintegrator (deflaking)
 Bottom left: Screening (accepts)
 Bottom right: Screening (rejected material)



Above: Sample of Google packaging undergoing repulping testing at Western Michigan University.

We collaborated with Western Michigan University (WMU), leveraging their expertise at the Paper Pilot Plant, to certify recyclability for our coating, varnish, ink, and paper combinations. The Fibre Boxboard Association test protocol for wax replacement corrugated containers guided this process.

The certification protocol involves two distinct phases:

Lab scale testing

- Testing repulpability to ensure material breaks down for a minimum 80% yield without operational issue.
- Testing deinkability (ISO 21993:2020/INGEDE Method 11) to test removing coatings or inks in the paper recycling process.
- Testing for the presence of “stickies” which are paper contaminants classified as tacky. Examples include waxes, coatings, and soft adhesives.

Pilot scale testing

- **Simulates real-world conditions**
Minimum 200lb of test material is processed alongside control paper stock.
- **Comprehensive score**
Evaluates operational impact, yield, color, strength, and stickiness of recycled fibers.

Coating solutions



Above: Sample deflaked on disintegrator.



Above: Fiber accepts after screening during repulpability test.

Our PP lamination-free solutions were extensively tested and successfully met our operational and optical/mechanical performance criteria.

This testing included running recycled pulps from Google's new plastic-free printed packaging designs alongside unprinted paper stock and our original PP laminated solution for comparison purposes. While both Megami varnish and Actega coating passed the recyclability test and met our performance requirements, **we have deprecated the Actega coating solution** due to some manufacturing challenges that our team is actively working to resolve.

The Megami varnish has been successfully implemented at scale. Details on these scalable solutions can be found in our [Material Library](#).

As collection and recycling infrastructure for fiber-based packaging changes, design modifications and collaboration with producer responsibility organizations will be important to ensure high acceptance rates. Our intention is to understand the criteria and assessment methods being developed and optimize our packaging solutions for seamless integration into evolving recycling streams.

Coating solutions

Our coating qualification process

While qualifications will vary greatly by company and product needs, below is Google’s process to ensure our suppliers deliver consistent, high-quality coatings.

We employ a 6-phase qualification plan emphasizing compatibility, print excellence, real-world performance, and a commitment to continuous improvement.



Phase 1

Initial vetting

- Technical Data Sheets (TDS) and Material Safety Data Sheets (MSDS) review to verify alignment with our safety and environmental standards
- Coating and ink vendors compatibility testing, particularly for specialized print needs
- CTQ – early scuffing and bend resistance data as primary indicators of performance
- Repulpability, recyclability, and deinkability tests aligning with our environmental goals

Phase 2

Printing excellence

- G7 color management for consistent color reproduction
- Quantifiable cosmetic standard for defects with variable tolerances based on visibility

Panels less than 200mm x 200mm

Defect size	Cosmetic class			
	LOGO	A	B	C
<0.08 mm ²	2	3	OK	OK
0.08-0.2 mm ²	NG	2	OK	OK
0.2-0.5 mm ²	NG	1	2	OK
0.5-≤ 1.0 mm ²	NG	NG	1	OK
1.0 - 3.0 mm ²	NG	NG	NG	1
> 3.0 mm ²	NG	NG	NG	NG

Coating solutions

Phase 3

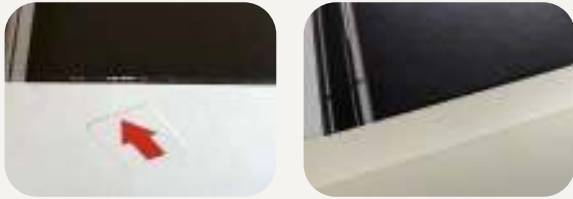

Laboratory testing

In-depth testing for abrasion resistance, fold cracking, alcohol and water resistance, and adhesion

Phase 4

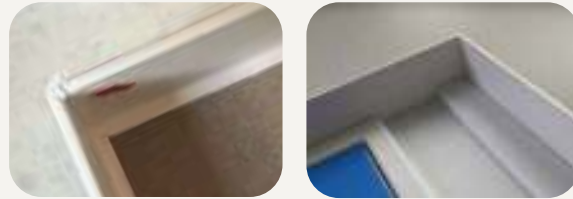

Box assembly

Monitoring for potential assembly issues like deboss cracking or corner bunching, optimizes production setup

Phase 5



Contract manufacturer test

Full assembly simulation at our packing lines identifies potential cosmetic issues and assesses compatibility with labels and downstream processes.

Phase 6



Reliability testing

Comprehensive vibration, drop, environmental, and cosmetic testing ensures the coating withstands supply chain and user conditions.

Coating solutions

Opportunities for improvement



Above: Ink residual spots of deinked pulps

Improving deinkability

Exploring ink/coating pairings that further minimize ink residuals after recycling could yield even higher quality recycled fibers.



Above: Pixel box at the gluing process

Fold/score protection

We continue to research coatings with even greater flexibility to prevent artwork damage during folding while maintaining recyclability, ensuring a flawless presentation from production to store shelf.

Coating solutions



Key insights ¹

Our journey to replace plastic lamination with coatings taught us valuable lessons about material interactions, print quality, and supply chain management. Here's a look at some key insights we've gained so far:

- **Our final coating choice** exhibited comparable abrasion and fold/score cracking resistance to the PP laminate, ensuring artwork protection. It also preserved cosmetic performance and visual appeal essential to our brand standards.
- **Strong adhesives** used on closure labels meant to ensure tamper-evidence could damage the box surface upon removal and compromise product presentation. We tested many to find options that would avoid damage with our coating solution.
- **High-tack UV offset inks**, while essential for coating adhesion, could cause paper picking if paper surface strength is insufficient. We tested paper sources and established surface strength benchmarks (wax pick method) of 13+ for coated grades and 18+ for uncoated grades.
- **UV offset inks** have a narrower process window for fountain solution-ink balance when compared to conventional offset inks. If UV inks are emulsified excessively by the fountain solution, it can lead to irregular dot shapes. We proactively optimized fountain-ink balance during printing, minimizing fountain solution and ensuring optimal dot quality.

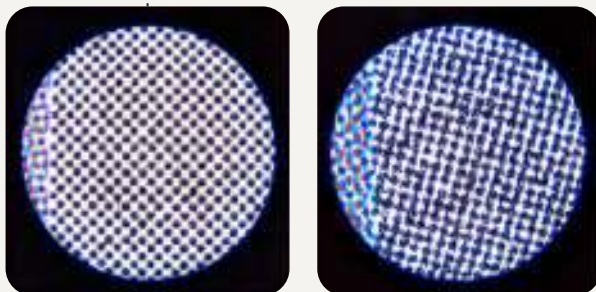

Above: Dot quality comparison between print runs to evaluate dot gain/shape.

Coating solutions



Key insights ²

- **Storage conditions and pre-mixing procedures** for coating materials can significantly impact coating performance and machine efficiency.
- **Real-world shelf-life for a coating material** is determined by the unique coating formulation and may differ from the technical data sheets of individual chemicals in the formulation. We developed specific operational requirements to manage the shelf life of our specific formulation.
- **When testing various coating solutions in a large-scale stress build**, we discovered that machine cleaning requirements could disrupt production. We eliminated options requiring more frequent cleaning to avoid costly production problems.
- **We partnered with our vendors** to enable production scalability and consistent supply of sustainable packaging solutions. This collaboration reduced the initial investment needed for development and testing. These solutions are now readily accessible for use by other brands with details available through our material vendors.



Printing press: Manroland R700



Shrink wrap removal

Plastic shrink wrap, while versatile, poses significant recycling challenges.

It's difficult to effectively separate from other materials in recycling systems, offers limited value for recyclers, and ultimately has a high chance of landfill disposal.

Challenge

* * * * *

“Shrink wrap was been an industry standard way to create tamper evidence and closure, but in designing a more recyclable alternative I think we created an even better unboxing experience.”

- Charlie

Structural Packaging
Design, Innovation Lead



Shrink wrap removal

Our approach

To replace shrink wrap, we made several key packaging design changes to maintain product protection, tamper-evidence, and a premium aesthetic without compromising our sustainability goals:

- UV protective coatings safeguard packaging artwork from abrasion.
- Specialized adhesives for fiber-based closure labels provide a strong, tamper-evident seal. Closure labels were not previously needed with shrink wrapped products.
- Structural design revisions on all box styles compensate for the loss of tensile strength that shrink wrap provided.



Success criteria and testing

- Our packaging undergoes extensive reliability testing, including vibration, drop, environmental exposure, and compression simulations. This ensures that consumers receive products in pristine condition, even without shrink wrap.
- Cosmetic performance is evaluated through rub/abrasion tests and supply chain simulations. These guarantee the package maintains its visual appeal throughout its journey.
- Recyclability (repulpability, deinkability, etc) testing ensures our packaging has improved compatibility with paper recycling systems.



Shrink wrap removal

Key insights ¹

Structural evolution for plastic removal

The Roll End Lock Front (RELF) box style poses unique challenges when eliminating shrink wrap different from those for telescoping boxes and tuck-end cartons. This section focuses on considerations for RELF and corrugated boxes, highlighting strategies to maintain both structural integrity and visual appeal without plastic wraps.

Top sheet appearance

To achieve a premium unboxing experience, we've prioritized a high-quality top sheet for corrugated structures. This ensures a smooth, visually appealing surface while minimizing the prominence of corrugated ribs. Additionally, using F-flute corrugated material reduces rib visibility and can be balanced with other structural and cost requirements.

For an even more polished presentation when the box is opened, a color-matched inside liner can further mask the ribs. These refinements are especially important when shrink wrap is removed, as they maximize abrasion resistance and maintain a high-quality appearance throughout distribution and on-shelf display.

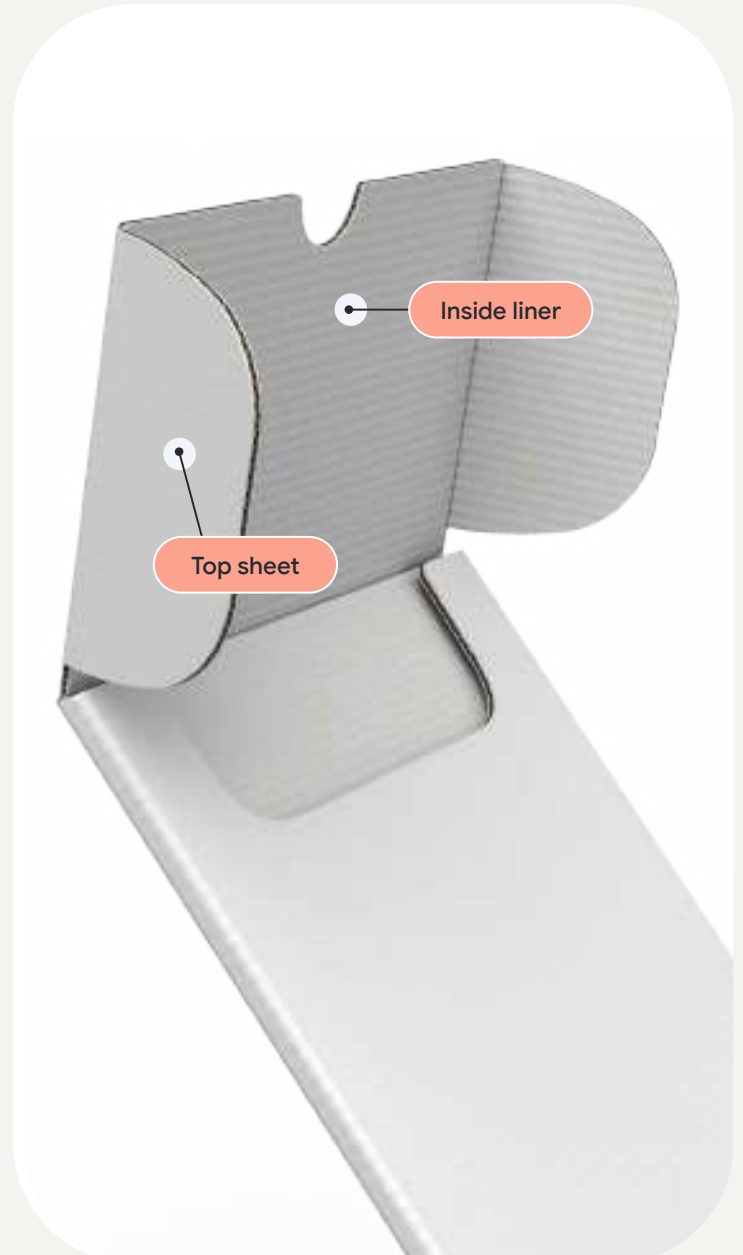

Shrink wrap removal

Key insights ²

Shrink wrap, while creating a unified package, can mask potential structural weaknesses. Without it, it's vital to ensure that large panel elements, particularly the lid, maintain their integrity to protect the product and preserve a pristine appearance throughout the supply chain. **Here are four key strategies:**

Maintain lid integrity

1: Lid stiffeners

Drop testing may reveal bowing or stress marks on the RELF box lid. If that occurs, it's essential to add a stiffening element. Greyboard, a recyclable option made from recycled material, is effective when starting at 1mm thickness.

2: Molded fiber versatility

If a molded fiber tray is already part of the design for product support, its flange can be extended to improve lid stiffness. In some scenarios a modest flange extension is sufficient, however extending it to the entire lid may further increase support.

The visual on the right demonstrates how a short flange can be adhered inside the lid (lower image) to hide it in the final assembly.

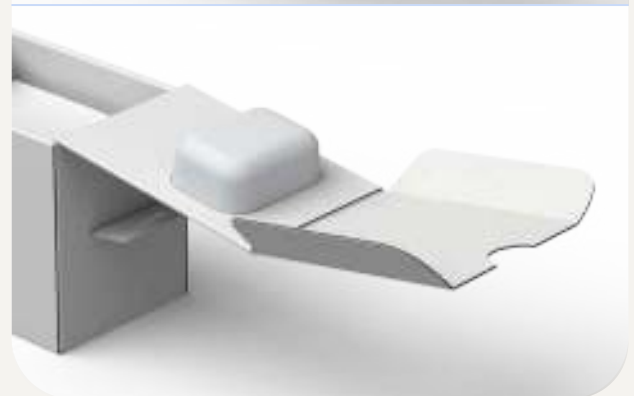
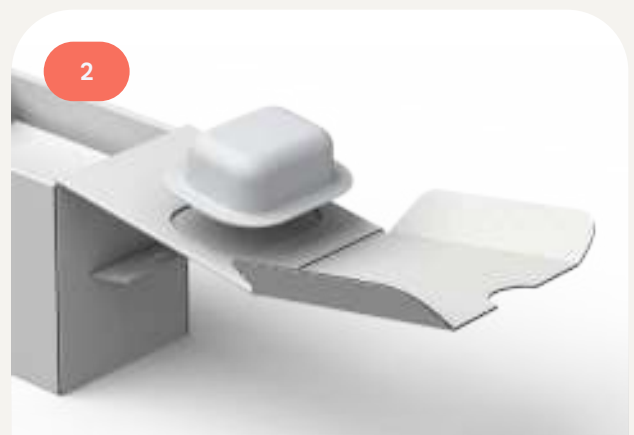
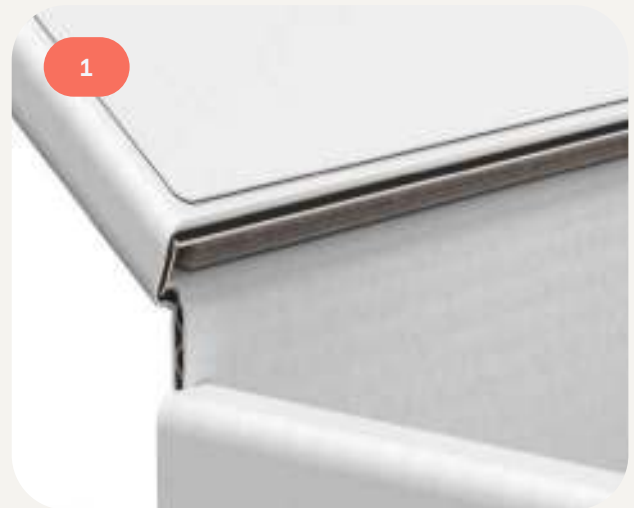

Shown: Flange extends into lid for structural support.

Shrink wrap removal

Key insights ³

Preserve box cosmetics

3: Shipper adjustment

To minimize abrasion and maintain the pristine presentation of the retail box, we flip the orientation of the corrugated shipper's liner. This ensures the smoother, thicker kraft paper faces inward, in contact with the finished box surface, rather than the exposed corrugated ribs.

4: Gentle protection

When necessary to further minimize abrasion, a thin layer of tissue or kraft paper can be inserted between retail boxes within the corrugated shipper. This creates a gentle barrier, preserving the pristine packaging surface, while remaining compatible with paper recycling streams.

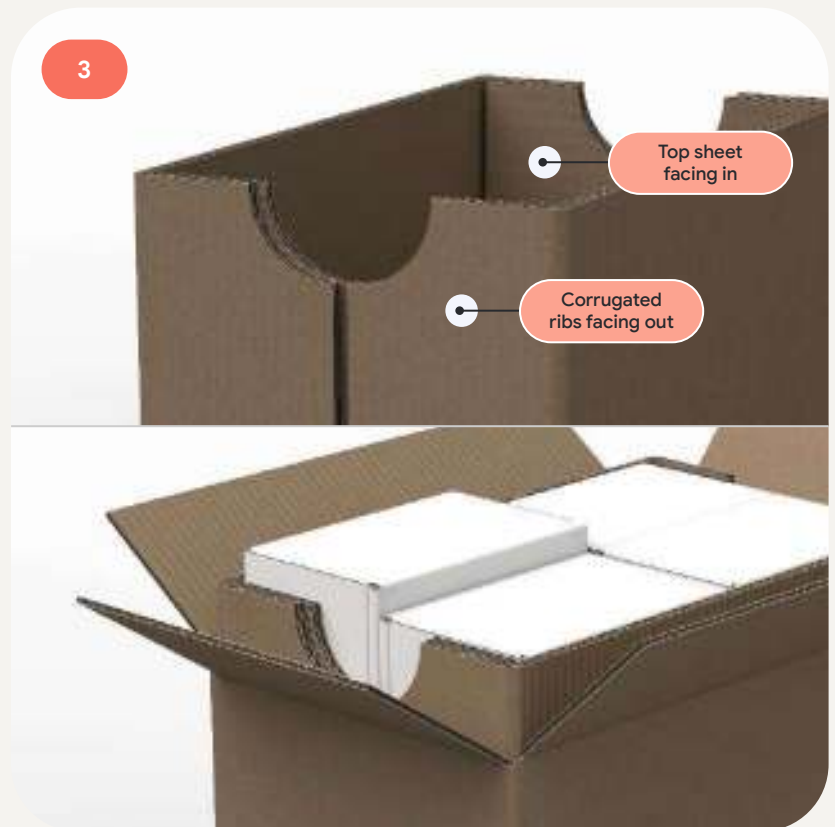



Closure mechanisms

Box closure is a challenge for some structural formats without the use of plastic shrink wrap.

Many box styles offer built in closure mechanisms, but others require design modifications or creative additions to meet specific product needs. Considerations such as product weight, unboxing experience, rework, cost, and the need for tamper evidence can introduce additional complexities. Above all, the ability of a package to securely contain and protect the product inside is paramount.

Designing a cohesive brand packaging experience across a diverse product portfolio was a challenge but also an opportunity. We designed a new closure system where multiple packaging elements work together to achieve simplicity, strength and high print quality.

Challenge

* * * * *

“We’re aiming for the right blend: packaging that uses sustainable materials, an efficient design, and impactful product graphics.”

- Amy

Packaging Graphic Designer



Sleeves

Our approach

We've incorporated a four-sided sleeve onto our packaging that allows for high-quality, full-color imagery of our products. In a retail environment, accurate print color on the front of the pack, particularly for lifestyle or product images, is crucial. The substrate used for printing plays a significant role in achieving this.

While our new uncoated paper is a milestone in recognizable recyclability, some aspects of product packaging require materials optimized for printing. While we continue to explore printing solutions for uncoated paper, our coated paper product sleeves are still 100% plastic-free and recyclable while providing an excellent surface to print photorealistic images.

Despite the addition of the sleeve, our overall packaging mass is reduced compared to our 2023 packaging design due to the exceptional strength and light weight of our custom paper, allowing us to achieve a thinner, more efficient packaging solution.

The sleeve is a packaging component that can allow for content customization late in the supply chain process. This enables us to streamline our box designs resulting in higher minimum order quantities (MOQs) and reduced waste. This approach provides greater flexibility and reduces the need to produce and stock many different pre-printed boxes.



Sleeves

Success criteria and testing

Color reproducibility

We chose Iggesund Invercote G paper for its exceptionally smooth and uniform surface designed to improve quality on the coated printing side. Its glossy, white, raw material enabled us to achieve more color consistency and the accuracy we were after.

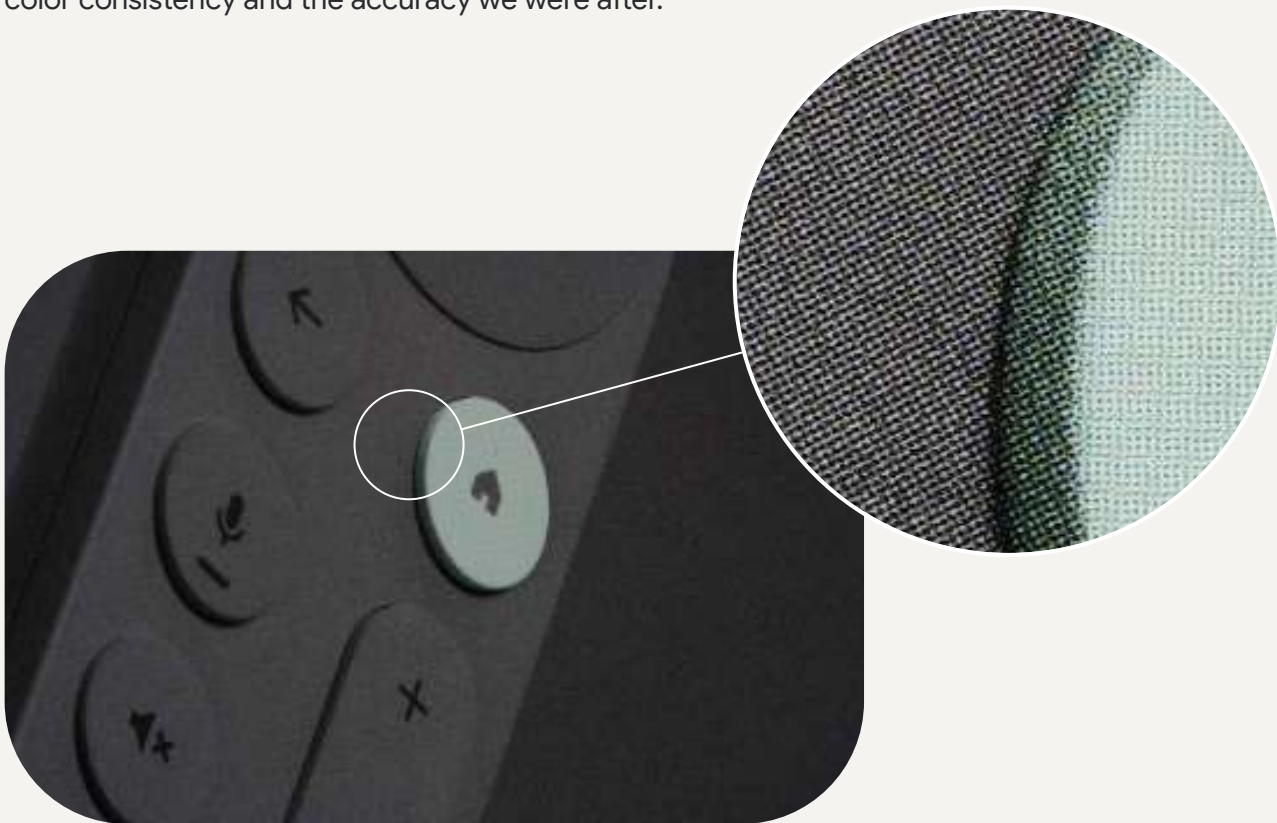

Shown: Magnification of G paper halftone rosettes

Sleeves

Success criteria and testing (continued)

Score cracking

Invercote G paper also provides high resistance to score cracking, which was important for our graphics that are designed to flood over the folding edges of the sleeve. The 240gsm Invercote G has a tensile energy absorption (TEA) that is over 1.5 times higher than the 300gsm Sun Paper used in our 2023 packaging design along with superior stretch in the Machine Direction (MD).

To validate score cracking resistance, we tested with three folds at 180° (simulating when sleeves are shipped flat) and five folds at 90° in the following configurations:

1. Crease line - MD
2. Crease line - CD
3. Reverse crease - MD
4. Reverse crease - CD

The 240gsm Invercote G passed all 180° fold and 90° fold tests in all configurations. By comparison, the 157gsm Sun Paper only passed configurations for 90° fold tests.

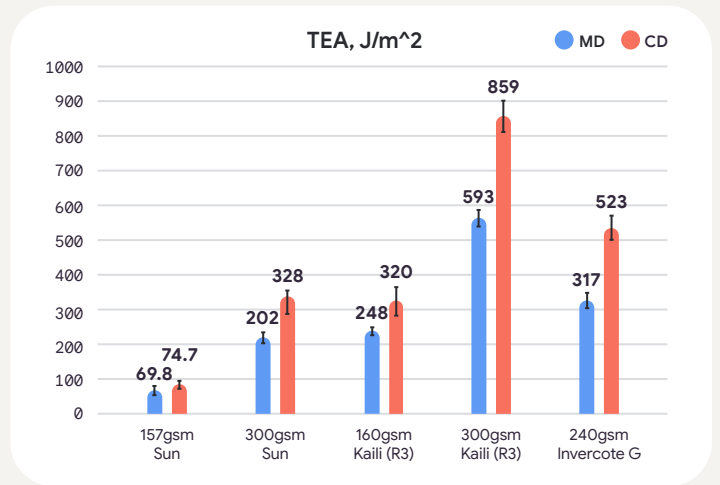
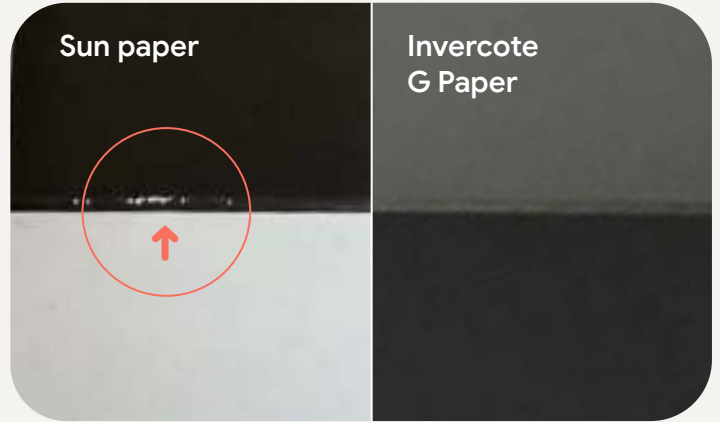

Above: Tensile energy absorption values of materials evaluated

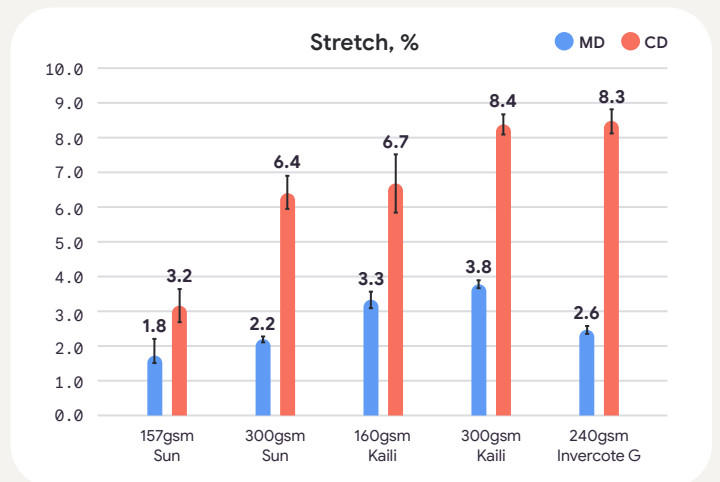

Above: Stretch material values among papers evaluated

Sleeves

Key insights ¹

Automation

Positioning, folding, and gluing the sleeve using automated assembly presented challenges and required investment in specially designed machinery and fixtures.

For automated assembly, we shipped the sleeve component flat and had it wrapped or formed around the box. We accepted a nominal cost increase by including a tab on the adhesive release liner to significantly improve equipment yield and rate. Such trade-offs need to be assessed on a case-by-case basis, aligning with vendor capabilities.

Sealing a manufacturing joint is a standard capability for many vendors. Automating this step to pre-fold and glue sleeves can ease assembly and improve quality where manual box integration is preferred.



Sleeves

Key insights ²

Fit

If a sleeve is used as a closure mechanism, it carries some trade-offs. A loose sleeve may appear low-quality, but is easier to slide off during unboxing. A tight sleeve looks polished, but can be a challenge to remove. Balancing fit based on package dimensions, brand needs and intended user is crucial.

It is also important to consider how sleeve fit changes over time and through testing or transit. Dimensional planning is recommended to account for environmental temperature and relative humidity that can cause sleeves to stretch.



Glue joint location

If a hag tab is used, moving the glue flap to the top can double the material thickness, increasing strength and reducing bowing once the pack is pegged. This is especially helpful on thin or heavy boxes where bowing of the top panel will be more dramatic. The Google team has selected Guanli MA-7601, a water-based glue, to secure the glue joint on the sleeve.



Peelable closure labels

Our approach

Our new peelable closure label is an evolution of the tear strip closure label. It retains the tear strip's familiarity and tactile feedback. However we took a different approach to balance user experience, discoverability, and accessibility with a simplified aesthetic that leaves no rough, torn edges or dangling flaps after opening.

Our new closure system combines a sleeve with a peelable label to provide both tamper evidence and box closure. Because box closure is heavily aided by the sleeve, the peelable label primarily keeps the sleeve in place and provides tamper evidence.



Peelable closure labels

Key insights ¹

Maximum flexibility

Instead of shrinkwrap, we were able to leverage the strength of the sleeve and use the same peelable closure label on a variety of boxes. A single label size could be sufficient for nearly all box types and sizes, but it must stay perfectly in place during transit.

Discoverability and aesthetics are also important considerations. For example, a very small label on a very large box may be difficult to find, especially if one has visual impairments. Our peelable label mechanism allowed for maximum flexibility and adaptability to accommodate many configurations.



Peelable closure labels

Key insights ²

Balancing specifications

To ensure optimal label performance, it is crucial to carefully balance the adhesive strength with the internal bonding strength of the paper. Any imbalance can result in subpar functionality, a negative user experience, and compromised aesthetics. Furthermore, it's important to incorporate tolerance in specifications for both adhesive and paper bonding strength. Overly narrow tolerances increase the risk of specification overlap, potentially leading to inconsistent performance and loss of design control.

Rework

The ability to rework an opened package should be considered during the design process. If rework is a requirement, it is beneficial to proactively plan the necessary procedures, tools, and potential impacts on logistics and operations.

Peelable label assembly

1. **Peel tab**
(100gsm Kaili Glory)
2. **Differential adhesive**
3. **Tamper evident remainder**
(100gsm Kaili Glory)
4. **Permanent adhesive**
5. **Release liner**

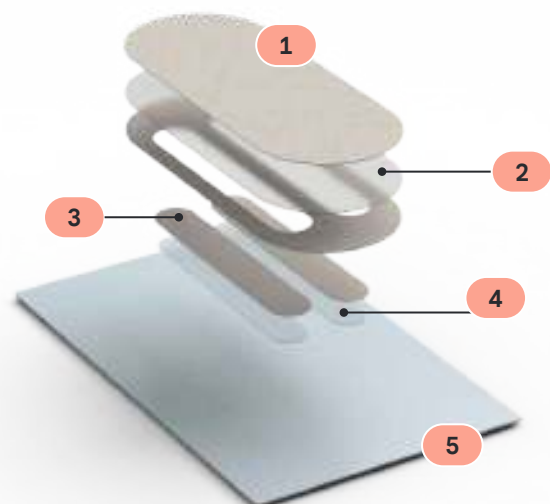
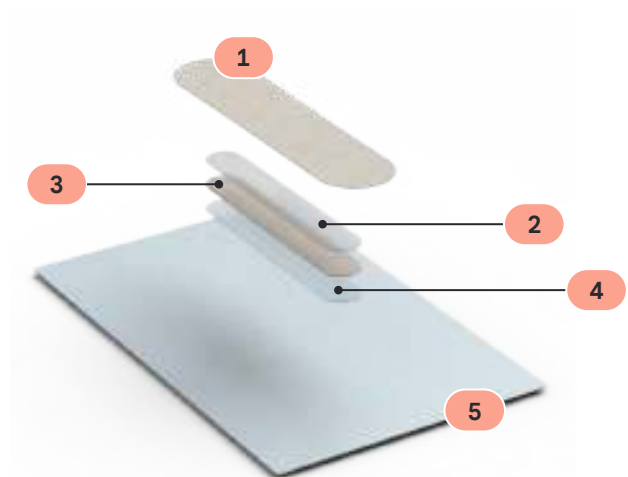

Tear strip closure labels

Tear strip closure labels are a practical and versatile solution for maintaining product integrity.

By prioritizing paper-based labels, we can reduce plastic waste and improve the ease of opening for everyone.

Inclusivity at the forefront

As we strive to create packaging that's better for the environment, we also want to create a more inclusive experience for consumers.

We performed user testing to understand the unboxing experience of diverse individuals. We partnered with 36 participants and actively included those with mobility limitations, vision impairments, alongside those with no specific accessibility requirements.

Our study revealed that paper closure labels consistently outperformed plastic ones in ease of opening across all participant groups. The plastic label was identified as the most difficult to open for those with visual impairments, likely due to its smaller size and lack of tactile differentiation from the box surface.

These results revealed to us that paper closure labels are an important consideration in designing accessible packaging. Their ease of grip and intuitive design appear to benefit users with varying dexterity and visual capabilities.



Our study revealed:

* * * * *

Paper closure labels are easier to open than their plastic counterparts.

Tear strip closure labels

Parametric design layout

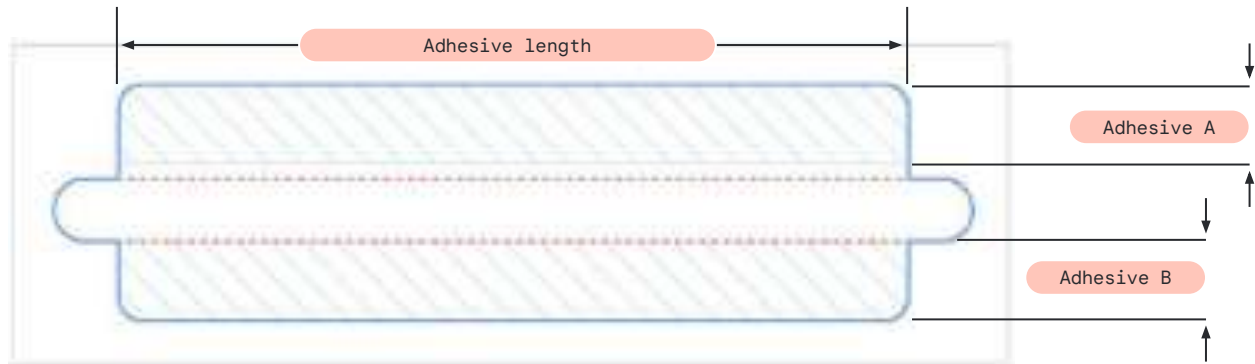

Geometry for protection and efficiency

- **Telescoping boxes:** Adhesive covers at least 50% of the lid's outer dimension.
- **RELF boxes:** Adhesive extends to at least 75% of the box's outer dimension.
- **Adhesive width:** A minimum of 10mm is needed for optimal adhesion during initial curing.

Accessibility: pull tab design

- **Minimum size:** 8mm x 8mm is recommended to balance visibility and ease of grip.
- **Trade-offs:** Larger tabs may impact available space for box graphics.

Parametric design layout

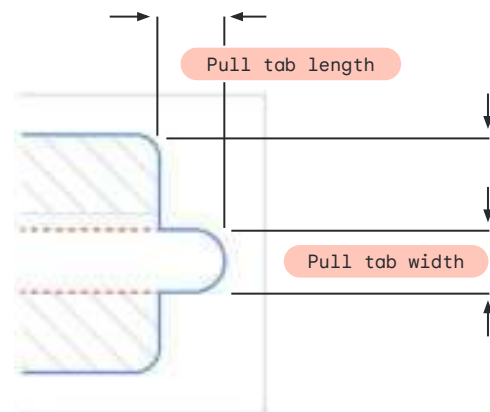

Tear strip closure labels

Key insights ¹

Deadening: Ensuring a smooth unboxing experience

A margin of deadened adhesive (non-sticky) with extra allowance on the closure side around the pull strip is crucial for a seamless opening experience.

Without it, telescoping box lids can become stuck, tuck-style closure may have residue, and pull tabs can have adhesive clinging to their edges, hindering functionality.

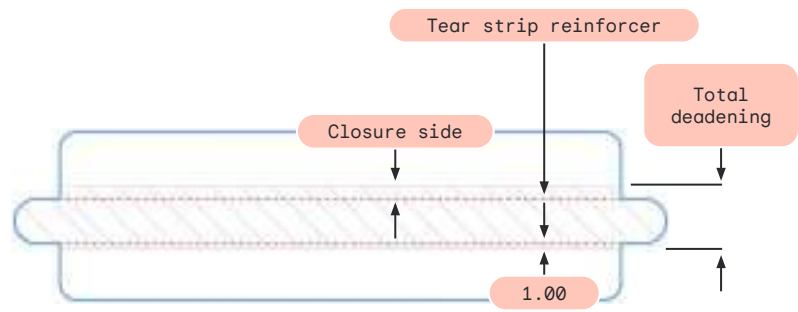

Deadening specifications:

- Minimum Width: 1.0mm, each side of the tear strip (tolerance +/- 0.5mm).
- Typical Extra Allowance Width: Approximately 2.0-2.5mm.

Starter slit

Our testing found that fiber-based labels do not require a starter slit to tear cleanly in reliability testing. Adding a starter slit may increase the risk of tabs accidentally ripping during handling.

This decision should be tailored to the specific production context. If a starter slit is used, we recommend a length $\leq 1\text{mm}$.

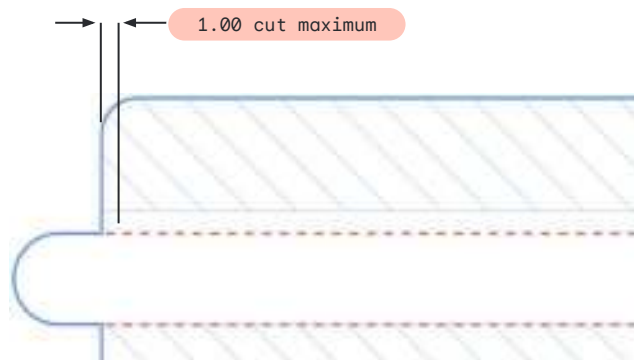

Tear strip closure labels

Key insights ²

Label face

The label paper must balance strength and ease of removal. Its grain should align with the tear direction to guide opening.

Tear strip reinforcer

This component requires especially high tear resistance. Translucent papers can offer this strength with minimal thickness, but their composition must be verified. Technical Data Sheets (TDS) and Material Safety Data Sheets (MSDS) should confirm that these papers are 100% plastic-free, with no regenerated cellulose.

Adhesive

A permanent adhesive is essential for tamper evidence. Thorough application with sufficient time and pressure ensures that part of the label remains on the box when opened. The choice of adhesive will determine the required surface area for proper bonding. If a larger bonding area is needed, but increasing the label size is not feasible, using glue assets can address this requirement.

Reliability

Labels must adhere securely but allow for a clean and continuous tear without tools. Vibration, drop, and environmental condition testing was used to verify label performance during shipping and handling. This testing also validates consistent, single-tear strip removal.

Label assembly

1. **Label face** (art paper)
2. **Tear strip reinforcer** (translucent paper)
3. **Adhesive**
4. **Release liner** (glassine paper)

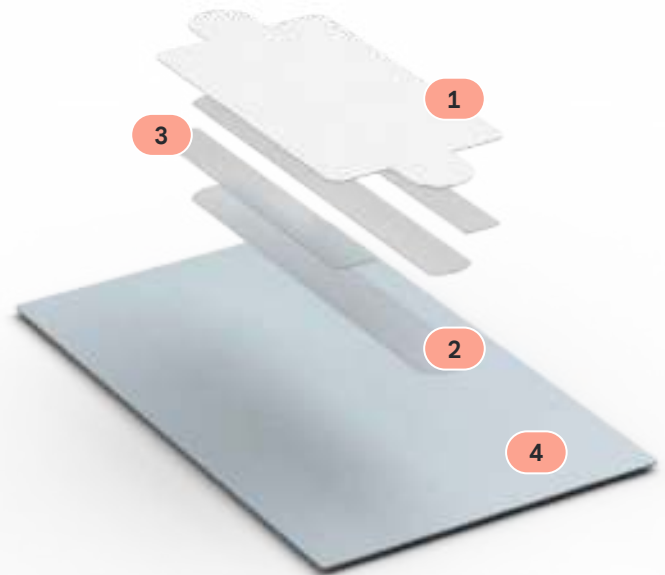

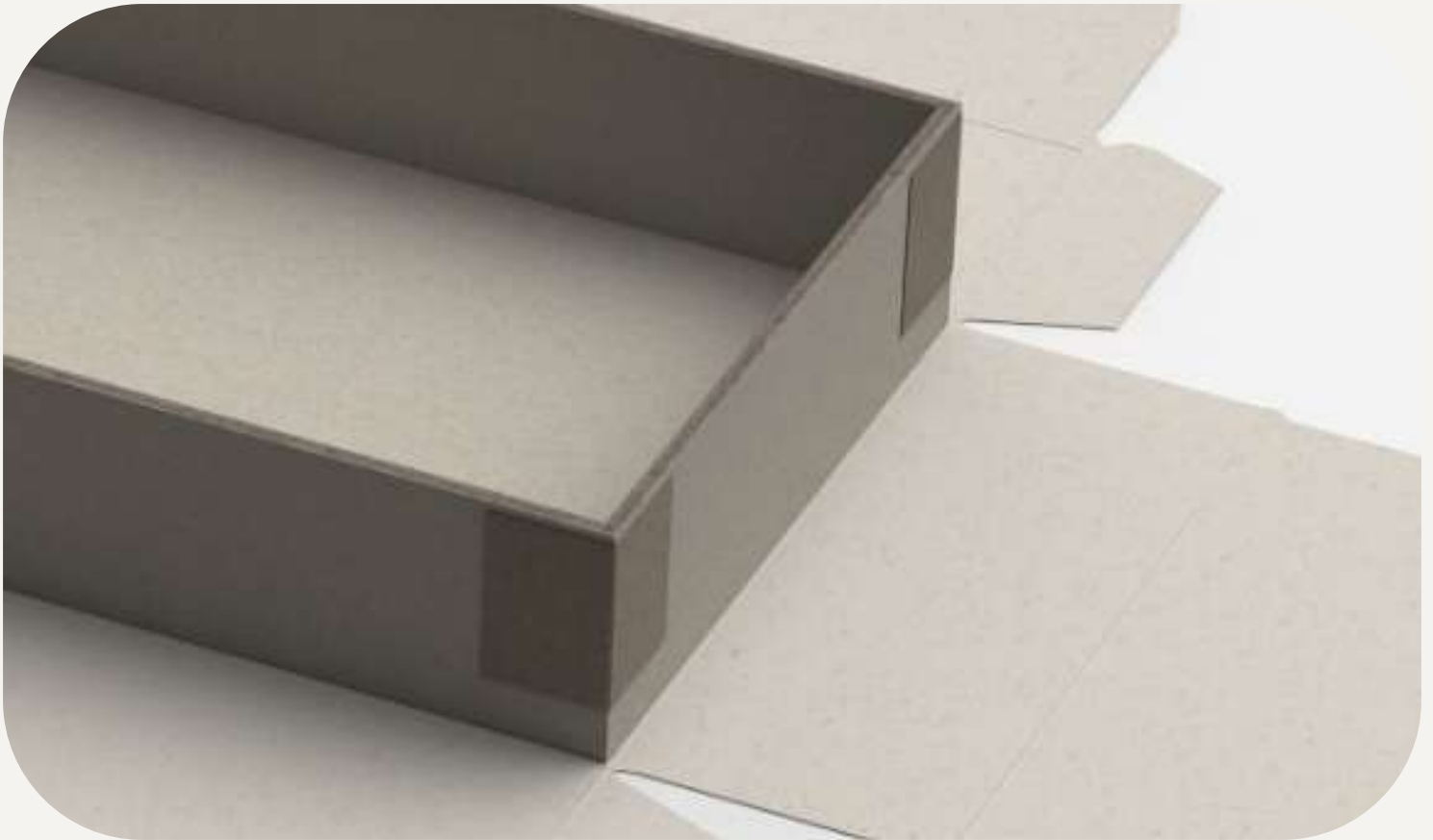

Paper tapes

Rigid box structures offer durable product protection.

Google's rigid telescoping boxes formerly used plastic corner tapes to provide tensile strength, but this also hindered recyclability.

Challenge

* * * * *

“We wanted a paper tape to replace plastic. It had to be strong, automation-ready, and still keep our products secured.”

- Yang

Packaging Materials Engineer



Paper tapes

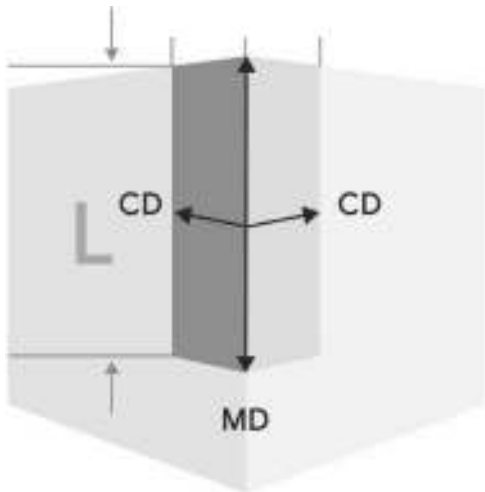

We successfully qualified **Brown Kraft Billerud Korsnäs (BK)** in 120gsm for its superior tensile energy absorption and passing our drop and vibration tests even for heavier products.

Our goal was to find a paper-based alternative that:

- Met or exceeded plastic tape corner tape performance.
- Was compatible with our suppliers' automated tape application process.
- Was readily available with a robust supply chain to avoid production disruptions.
- Had minimal thickness to prevent witness lines seen on the finished box.

A robust tape solution is essential to prevent corner tearing during a drop and ensure the vertical box walls stay perpendicular to the bottom panel. Higher tensile energy absorption provides better drop performance.

All papers used for tapes were qualified using tensile energy absorption in the Cross Direction (CD).

High fiber yield

* * * * *

BK Brown Kraft achieved a 99% fiber yield in repulpability testing, taking us closer to our goal of fully recyclable packaging.

Paper tapes

Key insights

Application

We deboss our greyboard by 0.25mm in the corners to hide the tape.

Eliminating tape visibility provides a cleaner aesthetic and improves our ability to control consistency of box opening time.



Desirability

We target a 2-5 second opening time for our rigid boxes in alignment with ISO 1156:2011 accessibility standards. This target is what we strive for, but some box designs may fall outside this range.

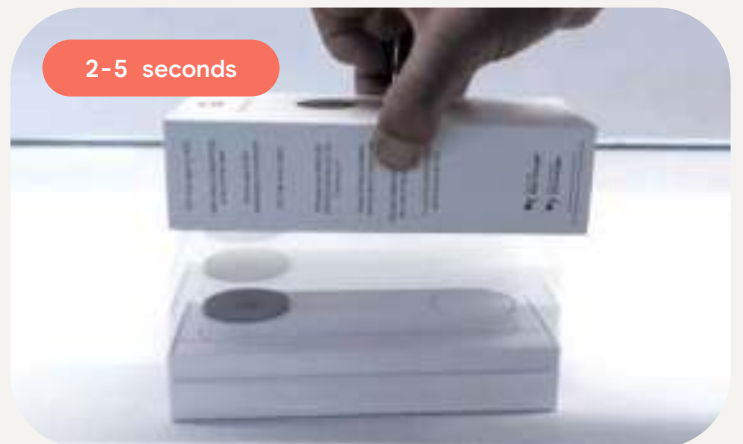



Hang tabs

Hang tabs offer benefits for both retail display and the overall customer experience:

- Hang tabs enable organized and eye-catching product displays creating visibility for consumer discovery and providing visual and tactile interaction.
- Robust hang tabs help deter theft and maintain product integrity.

Challenge

* * * * *

“Designing a hang tab that’s both strong and recyclable was a challenge, but it pushed us to explore innovative materials like molded fiber. We’re proud of the results and the positive impact it will have on the environment.”

- Miguel

Packaging
Sustainability Lead



Hang tabs

Putting fiber hang tabs to the test

To find plastic-free hang tab solutions that perform as well as their plastic counterparts in a retail context, we conducted testing to evaluate:



Strength and durability

Pull force testing to failure and 20-day double-weight performance benchmarks to measure reliable product weight support

Recyclability

Repulpability tests to confirm that tabs break down seamlessly with other paper-based materials

Manufacturing compatibility

Confirming integration with existing vendor automation setups, avoiding costly retooling

Design versatility

Ensuring tabs could be folded parallel to the box surface minimizing wasted space within shipping cases

Pull force maximum strength on tabs materials

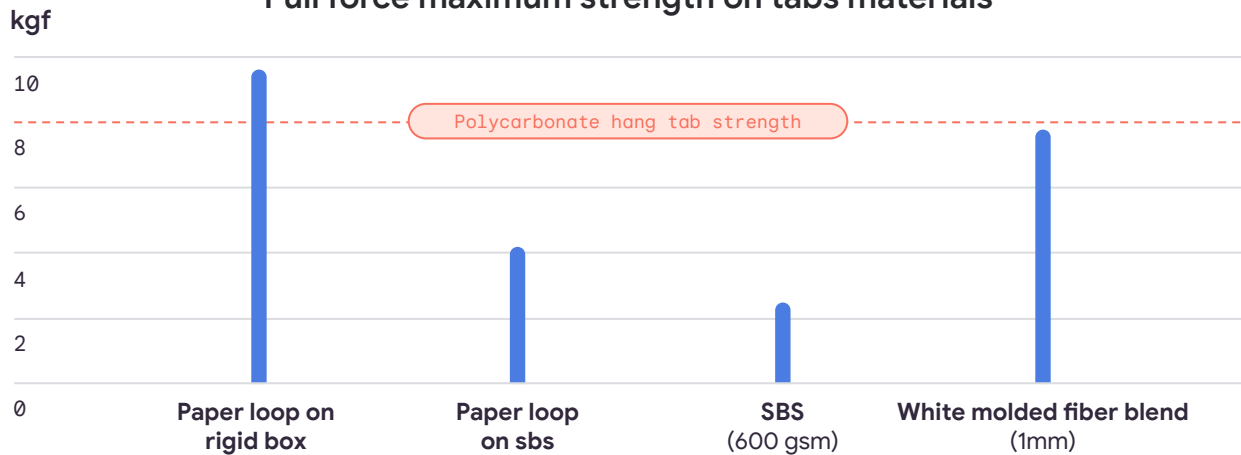

Hang tabs

Key insights ¹

We evaluated **five new** hang tab solutions, alongside our legacy polycarbonate plastic solution as a control.



1: Threaded paper loop

Created by interlacing a single strip of paper to form a sturdy hanging solution, this option exhibited an impressive 10 kgf pull force when assembled on rigid box but failed repulpability tests, did not meet automation requirements, and carried increased assembly costs.



2: Double-coated SBS paper

This option is made from paperboard with a smooth coating on both sides for enhanced durability and printing clarity. It could not however, withstand our maximum pull force requirements.

Hang tabs

Key insights ²



3: White molded fiber blend (2023)

Demonstrated strong performance, closely matching the plastic control at nearly 8 kgf pull force, and excelled in other critical areas. We successfully tested options at both 1 mm thickness (heavier products) and 0.7 mm (lightweight solutions).



4: Speckled molded fiber blend (2024)

Our new speckled molded fiber blend, launched in 2024, has replaced our previous material in hang tab applications. This updated formulation offers comparable strength to the original recipe at both 0.7mm and 1mm thickness.



5: Kaili Glory paper

We've been able to use our new Kaili Glory paper as either a single ply or dual ply hang tab design, capitalizing on the inherent improved strength of the material.

Hang tabs

Key insights ³

To replace plastic, we adopted molded fiber and paper based solutions for our hang tab materials. Our 2023 white molded fiber blend (reinforced) material was composed of 55% bamboo pulp, 35% bagasse pulp, 10% wood pulp. For our 2024 packaging our new Speckled molded fiber blend is composed of 66.5% bamboo pulp, 25.8% bagasse pulp, 5% recycled newspaper. For our lighter accessory products, we leverage the superior strength of Kaili Glory Paper.

These solutions achieved:

- Performance that matched plastic in tensile strength tests, providing a reliable merchandising solution.
- Packaging that could be recycled as a single unit without needing to separate the hang tab.
- A production-friendly solution with no retooling needed for a smooth transition.



Placement

The tab is placed over the product's center of gravity (not the center of the box) to ensure a balanced display with euro-style compatibility across various peg designs.



Hinge

A built-in hinge allows the tab to fold flat for efficient shipping.



Protective product wraps

First impressions matter.

Product wraps serve as the unsung heroes of the new design. They ensure devices arrive in pristine condition. Choosing these materials requires careful consideration to achieve both superior product protection and improved recyclability.

Protective product wraps



The functions of protective wraps in electronics packaging

Scratch and abrasion prevention

Protective wraps create a barrier, shielding product surfaces from scuffs and damage that can occur during transit and handling.

Dust and debris shield

These wraps maintain product cleanliness, preventing particles from settling within ports or openings.

Tamper-evident design

For consumers, an intact protective wrap acts as a reassuring sign of an untouched, brand-new product.

Gift-like unboxing

The right material elevates the unboxing process. Choosing a protective material for its visual and tactile qualities can elevate the excitement of unboxing a new product.

Enhanced accessibility

Product wraps can incorporate pull tabs or tactile signifiers (like textures or raised areas) to create a more intuitive, accessible unboxing process for all users.

Protective product wraps

Testing fiber-based solutions

We explored sustainable fiber-based solutions for several critical packaging applications. Our multi-pronged assessment focused on:

- **Abrasion resistance and surface protection:** Sutherland Rub tests (up to 100 strokes at 4lbs) against common product enclosure materials helped measure a wrap material's effectiveness.
- **Dust ingress:** Carefully evaluated to ensure a tight, protective seal. Evaluate material choices for potential to create dust within a package.
- **Ease of manipulation:** We studied how smoothly materials were removed and their suitability for wrapping various device shapes.
- **Consumer experience:** Assessing visual appeal, tactility, and contribution to "unboxing" excitement.
- **Recyclability & compatibility:** We prioritized options more compatible with paper/cardboard waste streams.



Above: Abrasion on a common enclosure material using a Sutherland Rub tester.

Protective product wraps

Testing fiber-based solutions (continued)

Our investigations have shown that fiber-based wraps can provide the protective qualities crucial for consumer electronics without relying on single-use plastics. They can also create an enjoyable unboxing experience.

We evaluated many materials and identified **four options** that can be effectively used for different situations requiring a protective wrap.

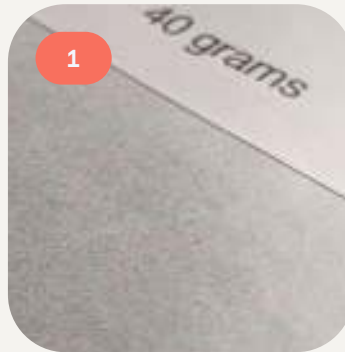

Supercalendered
paper (glassine)



Coated
wrapping paper



Translucent
paper



Low density
filter paper

Protective product wraps

Key insights

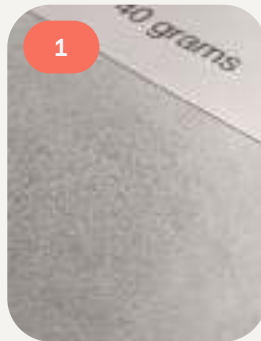

Supercalendered paper (glassine)

Scored well overall, except for average dust prevention
Suitable for general product/device wrapping

Because of the higher density and uniformity inherent in its production process, glassine paper typically generates less dust from its surfaces. Poor die cut quality can still pose a risk for dust, but can be mitigated with adequate production controls.

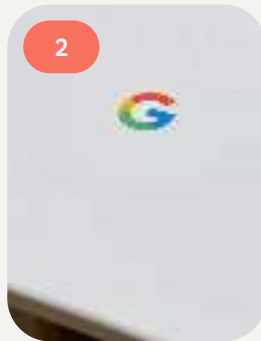

Coated wrapping paper

Performed better for dust, but overall average performance. A viable option for select use cases that do not require translucency.



Translucent paper

Ideal for bundling packaging documentation and adding an extra layer of protection. Some options have a similar aesthetic to supercalendered papers, but differences in production could lead higher dust generation. In practice, we have found that improved cleaning procedures during material production and handling can reduce dust generation.

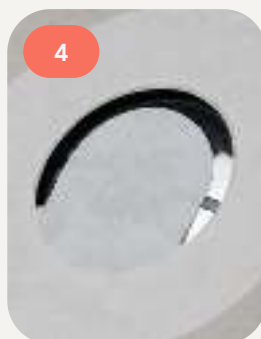

Low density filter paper

Strong all-around performer and soft-touch texture.
However, its slightly higher cost makes it best suited for when product surfaces demand maximum protection.

Protective product wraps

Shown:

Pixel 8 Pro packaging,
Fall 2023



Minimal adhesion

We prioritize product wraps that adhere to themselves or, even better, require no adhesive at all. When that isn't possible for specific products, applying wraps adjacent to packaging parts rather than the product itself can be an effective approach.

For our Pixel phones, we've chosen to adhere a wrap to the product, creating a more accessible design and an improved unboxing experience. In these cases we specify materials that eliminate unwanted residue.



Designing for a gift-like reveal

A translucent, rectangular piece of protective paper that wraps around and overlaps at the front of the product gives a gift-like feel, especially with a removable seal.

Flood printing the wrap with a solid color or pattern adds a design element that enhances the gift-like feel. This style will have some limitations based on product geometry and protective needs. The less rectangular a product is, the less likely this style will provide adequate protection.

Protective product wraps

Material composition verification and consistency

Because wrap materials have direct contact with product surfaces, taking the time to understand material composition and ensure it's consistency can be a critical factor between a failed solution and a successful one. Papers that can be accurately classified as plastic-free may also include ingredients or fillers (such as clay) which could damage product surfaces.

Ideally, a designer has the ability to review both a material's MSDS and TDS prior to testing. Ingredients that are similar or harder than product contact surfaces may need to be flagged for potential product damage risk. Additionally, ensuring raw material sourcing consistency can be vital to building confidence in a material candidate. If consistency cannot be established, it may be impossible to verify the material documentation. This same principle holds true for coatings and varnishes.



Protective product wraps

Diagnosing unexpected results

From time to time, failures arise during testing that can be very difficult to explain, especially if they seemingly have no predictable pattern of occurrence. It's understandable to intuitively attribute new issues to new material choices, but a closer look often shows a process problem, not a material one.

If they are available, FA tools such as fourier transform infrared spectroscopy (FTIR) and microscopy can be invaluable for focusing on the true root cause.

For example, a foreign particulate introduced from an assembly line lodging into a wrap's surface may cause abrasion, but could be unrelated to the wrap material.

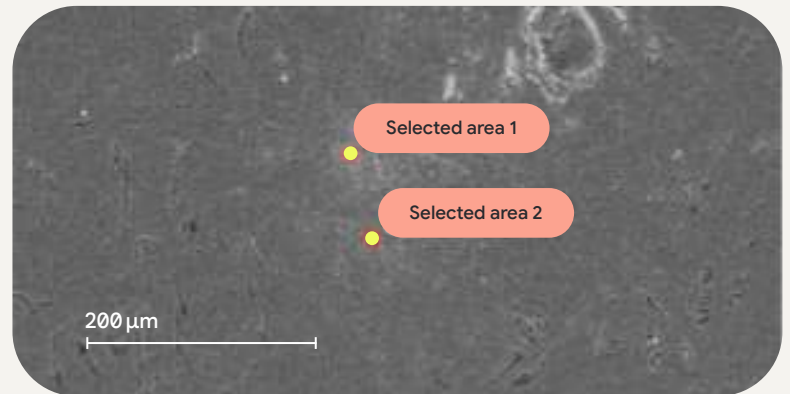

Above: SEM/EDS image of embedded particulate in paper

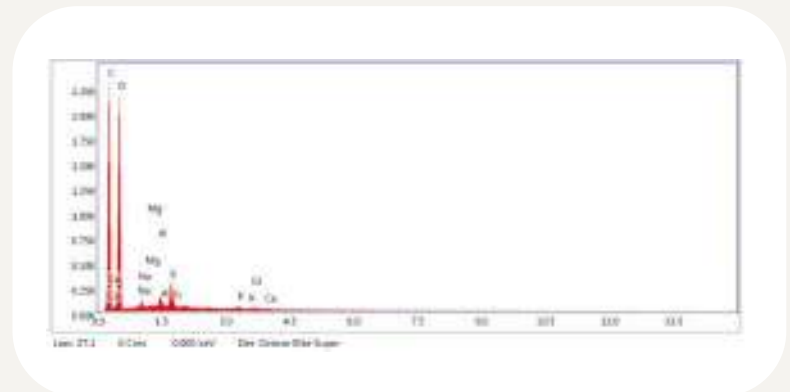

Above: Output of FTIR analysis of particulate composition



Inbox trays

Thermoformed PET trays have long been a staple to ensure higher value products are fully protected, but molded fiber offers exciting potential to merge recyclability advantages with premium functionality.

Molded fiber has cushioning properties that prevent damage during shipping and handling. Customizable shapes provide a secure fit, even for irregularly shaped items. Additionally, the tactile qualities of molded fiber may enhance the unboxing experience and product presentation.

Challenge

* * * * *

“While thermoformed plastic trays have their merits, we’ve found that molded fiber offers comparable protection with the added benefits of recyclability and a more natural aesthetic.”

- Rob

Packaging Design
Engineer Lead



Inbox trays

Tray types: Hinged trays

Benefits

- Precise cuts ensure a visually refined presentation and seamless integration with the surrounding structure.
- Structural stability minimizes warping, ensuring reliable product protection.
- High customization enables features like mirrored cavity geometry that can reinforce hinged panels for added strength and support.
- **Hinge style options**
 - Molded hinges are a cost-effective option integrating directly into the molded pulp tool during manufacturing and offering superior strength with slightly less precise dimensional accuracy after folding.
 - Post die-cut hinges, created by V-cutting pre-molded trays, deliver higher dimensional accuracy for a precise fold. They may have slightly lower strength compared to molded hinges and potentially increase cost.

Drawbacks

- Hinges require careful design to prevent tearing during initial and/or repeated folding.
- Hinged panels increase blank size (i.e. footprint) of a flat part during molding, which may increase part cost and reduce cavitation.



Inbox trays

Tray types: Skirted trays



Benefits

- High dimensional precision across production runs.
- Robust, stiff structure withstands handling and stacking.
- Potentially lower cost compared to hinged designs.
- Maximizes protective features while minimizing space within the package.

Drawbacks

- Draft angles can create a visual gap between the tray and enclosing structure.
- Risk of sidewall movement/flexing within the package without sufficient support.

Inbox trays

Tray types:

Flanged trays



Benefits

- Sharp cuts enhance visual appeal and fit within surrounding structures.
- Material efficient design option.

Drawbacks

- Large, flat surfaces are more susceptible to warping especially under load and in hot and humid conditions.
- Exposed tray edges may be more prone to scratches or dents.
- Lack of vertical walls increases the risk of tray (and therefore product) movement during shipping if the tray is not well secured.

Inbox trays

Tray types: Suspension trays

Benefits

- Allows the product to “float” with minimal contact against packaging surfaces when scuffing is a concern.
- Lends itself to easy product removal and a unique product showcase upon unboxing.

Drawbacks

- Depending on the geometry at the diecut location, matched metal dies may be needed.
- Requires a relatively specific product design that has anchor points where small molded fiber flanges can suspend the product.



Left:
Suspension tray cross section
with product

Right:
Example suspension tray



Inbox trays

Considerations for molded fiber trays

Strong supply chain partnerships

This ensures cost-effective solutions and reliable high-volume production. We analyzed supplier capabilities to inform tray designs.

Structural and visual optimization

- **Clean edges, secure fit**
Precise tray cuts enhance ease of removal, ensure stackability, and create a visually refined presentation.
- **Product interaction**
Subtle tray curvature can reflect product form, guiding natural placement and enhancing visual harmony.

Hinge functionality

We evaluated trade-offs between molded hinges and V-miter options based on cost, precision, and overall product presentation.

Consumer recycling

Adding recycling symbols on the trays promote responsible disposal.



Inbox trays

Key insights ¹

Maintaining consistency across device trays ensures stability and visual cohesion within a product package design.

Using different tray designs could contribute to reliability issues. For example, if one tray has more freedom of movement, it could cause undue surface contact with the device.



Inbox trays

Key insights ²

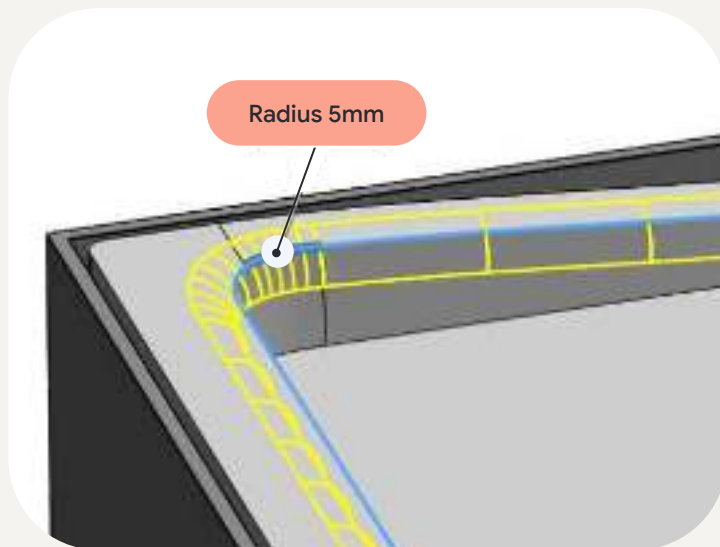

Tray cavity radii

Thoughtful design choices can balance a clean and visually appealing appearance with optimal functionality.

Because product abrasion risks are inherently higher with fiber-based materials compared to plastic, we recommend that radii transitioning from flat tray surfaces into product cavities be 5mm or less.



Tray marking

Including visible recycling logos on molded fiber trays can encourage more consumer recycling.

Inbox trays

Key insights 3

Pulp fiber recipes

Cosmetic molded pulp provides a smooth, consistent surface finish and can be molded into a wide variety of shapes and geometry for cosmetically significant trays. Different molded pulp manufacturing processes have varying degrees of finished part surface quality.

Once a manufacturing process is selected, we recommend using a standard slurry recipe to streamline production, control costs, and ensure a consistent, high-quality finish. Maintaining a standard recipe across multiple products reduces changeover and cleaning requirements during manufacturing.

Creating a premium packaging experience that maximizes recyclability has long been our goal. In some cases however, our fiber-based solutions have been so well made that they've been mistaken for plastic by consumers who then decide not to recycle them. In an effort to make it more clear that our molded fiber trays are not made from plastic, we've begun adding 5% recycled newsprint content to our slurry. This addition has a light impact on tray color, adds visible natural fibers and speckling, and complements the visual aesthetics of our new paper solution.

The visual distinction of our new speckled molded fiber blend serves as a visual cue to consumers, helping them readily recognize the material as fiber-based and recyclable. While developing this, we found it was critical to avoid over-processing the recycled newsprint. For our solution, slurry blending time is a critical parameter to control and we limiting it to ~15 minutes in our process.



Inbox trays

Key insights ⁴

Non-cosmetic pulp

For purely structural trays, consider using recycled materials like old corrugated cardboard / container (OCC) for enhanced strength, higher recycled content and lower part cost compared to cosmetic molded pulp solutions.

Materials like OCC typically produce parts with less desirable surface finishes, but have lower density and allow for thicker walls. This creates advantages for shipping and assembly, but may not be appropriate for product contact or consumer facing surfaces.



Inbox trays

Key insights 5

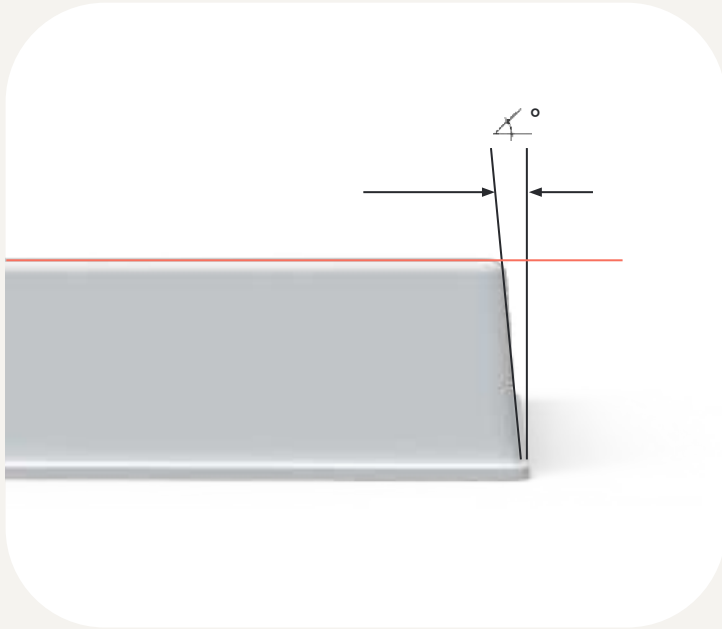

Precise fit

Steep draft angles can provide a refined aesthetic, but come at the expense of manufacturability and (in most cases) surface quality. On non-product contact surfaces, we recommend that draft angles ideally not exceed 4° . This allows also for a snug fit within the surrounding packaging, minimal gaps, and enhanced stability without sacrificing yield or part quality.

To further minimize gaps between inbox trays and the outer box, consider flanged or hinged trays.





Section 3.0

Structural design

Telescoping box →

Roll end lock front box →

Tuck top box →

Pouch →

Refurbished product packaging →

Retention pack →

Molded fiber outer box →

Sliding drawer box →

Isn't it just a box?

At Google, we carefully choose packaging structures to meet the unique needs of each product.

While we strive to create and versatile packaging designs, we also optimize different aspects of packaging performance for each product. These include product protection, cost, unboxing experience, and accessibility. Across our product portfolio we've created a variety of structural designs to meet all those needs.

Challenge

* * * * *

“Structural design is like a puzzle for me. Solving for sustainability just adds to the fun!”

- Cole

Structural
Packaging Design,
Innovation Lead



Telescoping box

(Rigid and paperboard)



- This box type features an elegant and classic aesthetic with clean lines ideal for showcasing higher value products upon opening. A telescoping lid offers a simple opening and closing mechanism. Custom inserts and collars can be added for a tailored unboxing experience.
- Provides excellent structural stability and a secure fit. Rigid versions may occupy more recycling bin space due to its non-collapsible form. Paperboard versions are more easily broken down to enable more efficient recycling (i.e. made to lay flat).
- Rigid box versions are typically constructed with greyboard (a high-strength recycled board). Paper tape is applied in the corners, and the box is wrapped in a paper top sheet. Various alternatives to greyboard exist, including the use of corrugated, laminates, and more. Paperboard is commonly used for lighter products, offering a smooth surface for printing. For heavier items, corrugated inserts (E or F flute) can help provide additional structural support adding rigidity and shock absorption.
- Some aspect ratios in this format present limitations. For example, telescoping structures with very large footprints can become difficult if not impossible to open with one hand and deep boxes can take a long time to open especially if the product is lightweight.
- While many suppliers can automate construction to reduce cost and tighten assembly tolerances, it is not universal. Handmade versions may involve more complex assembly.
- Where possible, pre-assembling inbox components in the rigid box structure can reduce logistical and manufacturing costs.

Roll end lock front box

(RELF)



- A versatile structure featuring a front panel with interlocking tabs for closure. The design offers a balance between protection, familiar opening and easy assembly. Can be designed to break down easily for more efficient recycling.
- Intuitive to open and can often be re-closed if needed. Effective where single-handed opening is desired.
- They come in a wide range of sizes, but may have limitations for very deep products. Larger blank sizes can easily be broken into multiple panels to accommodate equipment limitations. Thoughtful placement of seams helps maintain good aesthetics. Alternative designs like the Econo Roll End Lock Front Box are available.
- Constructed from materials such as paperboards or various corrugates. Material choice and/or reinforcement should be informed by intended use, product weight and scale.

Tuck top box



- Simple, functional appearance featuring a top flap that tucks into the box that is easy to open and close.
- Highly cost-effective and widely used for smaller accessories and lower priced products offering basic protection and easy assembly.
- Highly efficient to manufacture and ship flat.

Pouch



- Simple construction provides a structure that can be assembled on common automation equipment and shipped flat.
- Leveraged primarily for products that are lightweight, lower cost, and merchandised on hang pegs.
- Laminated paper panel adds rigidity and provides a high quality print surface for full color graphics
- Mechanical closure allows flexibility to optionally include an additional closure label. Particularly relevant for products that consumers may interact with prior to purchase - for Google, this includes items such as a phone case.
- Flexible design can accommodate a wide range of aspect ratios. For boxes with shallow depths, a hang tab can be integrated directly into the structure using a gable to reduce cost and assembly.
- When a hang tab is not required, the gable can be removed to yield a structure closer to a tuck top box, but with a more unique closure system.

Refurbished product packaging



- Outer box is a standard RELF, constructed of lightweight kraft corrugated
- One-size-fits-most design provides a “universal” solution for Google’s refurbished phone offerings.
- Inside the box is a kraft corrugated insert with a laminated kraft paper “wrap.” When assembled, the wrap secures the product using the principles of a retention pack design.
- Proper insert-to-box sizing is critical to performance. If the insert is too loose, the walls won’t stay vertical and the wrap won’t hold tension.
- Corner cut outs on the wrap provide critical relief for drops. Adding these cutouts helps avoid material damage and concentrated contact points on the device.
- No additional adhesive required for assembly and sealing. This means the packaging can be easily opened and broken down flat for recycling.
- Device pouch helps eliminate product abrasion and enhance the unboxing experience.

Retention pack



- An inbox component consisted of a hinged/foldable insert with a conformable “cover.” Ideally the cover material is thin, with good flexibility and tear resistance. Inserts can be a variety of materials such as corrugated or molded fiber.
- Provides controlled product restriction without the need for a second tray (or other custom component). Because the surface under tension is conformable (to a degree) it is less susceptible to issues caused by product changes.
- Evenly distributed product pressure via a thin fiber surface with significantly less material usage vs. two trays.
- Achieves a similar pre-load as some retail product box designs
- Allows the entire insert (or tray) to be removed as a unit with little to no risk of products falling out prematurely
- Technically doesn't need an outer box structure to function
- Compatible with many cover and product protection material options.
- Balancing surfacing bonding strength of your substrate with the adhesive peel strength is critical to optimizing UX.

Molded fiber outer box



- The use of molded fiber to create the outer retail box of a package structure allows for more organic shapes, especially on corners and edges. It also allows for the development of a particular pulp recipe to give a unique look on-shelf.
- As an outer retail pack, however, molded fiber could be more susceptible to damage in transit, particularly at raw edges. Thus, care would need to be taken to ensure geometry, wall thickness, and shipping carton design are considered.
- Molded fiber will also require draft, typically around 2-3 degrees for cosmetic application, which would need to be taken into consideration in the design intent.
- Molded fiber also could lead to a lower pack-out cost/effort because the cavities and overall geometry are formed as opposed to folded and assembled. However, the trade off is that parts are bulk shipped to manufacturers without being able to knock down flat, leading to larger shippers and possibly increased shipping cost. One way to mitigate this is utilizing the molded cavities for corresponding shipments. For example, if inbox documentation will use a molded fiber tray cavity, the documents could be placed in the tray as a sub-assembly before bulk shipping to final assembly facilities.
- In addition to simply molding in cavities as opposed to needing to assemble or set up inserts as is used in carton-based designs, molded fiber lends itself to certain mechanical features as well - such as locks and pegs to keep parts together.

Sliding Drawer Box



- This style of packaging is essentially a re-interpretation of the telescoping box in the sense that the “telescoping” action takes place horizontally as opposed to vertically.
- This allows a simple construction but with a new way to reveal product in a more linear or gradual way.
- The most straightforward execution of this packaging style utilizes a 5-sided tube or “body” and a 4-sided base tray or “drawer.” This allows the draw to be pulled out of the body in a single direction. Alternatively, the body piece could also be 4 sided to allow the drawer to be pulled out or be pushed out.
- This style of packaging could also employ two separate drawers to showcase multiple parts or accessories.
- The body and drawer elements could be made as “rigid” pieces, using a similar construction to a set-up box, or it could be made with only paperboard. Using the rigid construction style allows for variability in wall thickness.
- Requires a feature or structure to keep the drawer situated within the body tube until the intended unboxing.
- Requires a feature or tab to allow for drawer removal.
- In automated assemblies, tolerancing between the drawer and tube needs to be considered and balanced, similar to the tolerancing needed between a traditional telescoping box base and lid.

Structural design

Key insights

- **Volume optimization** – Logistics and shipping both carry cost to both packaging and the environment. Right sizing packaging, nesting box content, and volume optimization are effective ways to reduce these costs. This can be difficult to balance against requirements like product protection, brand requirements, and user interactions. However, creative solutions can yield substantial benefits. Some examples include:
 - Moving toward an edge-to-edge design vs. including a “frame”
 - Creatively leveraging product geometry to nest inbox content
- **Accessibility considerations** - Discoverability, single handed open, product access, and intuitive unboxing order.





Challenge

* * * * *

“Time is of the essence for our planet and it just makes sense to share knowledge. We have a common goal.”

- David

Lead for
Environmental
Strategy



The power of collaboration

Innovation can come from anyone or anywhere, but industry transformation involves everyone. We believe that by sharing our experiences, findings, and challenges, we can catalyze progress in our industry and others. What we’ve achieved isn’t perfect, but we hope it’s helpful and we’re eager to learn from solutions that others will create.

We’re excited to foster a community on our collective journey to create a future with sustainable products and services. By sharing design and engineering excellence, we believe we can protect the health of our planet and everyone on it.

Let’s collaborate to make that goal a reality.
packaging_sustainability@google.com

Glossary of terms



Accessibility

Designing for users with varying abilities and dexterity.

Cavitation

The number of cavities present in a molding tool. The cavitation number directly tells the expected number of parts produced each time the tool is cycled.

Closure label

A label with adhesive, used to secure packaging and provide tamper evidence.

Critical to quality (CTQ)

A concept in the Lean Six Sigma methodology that describes a product or process's most important and measurable characteristics.

Cross Direction (CD)

The dimension of a sheet of paper that is perpendicular to the machine direction

Debossed

A technique to create a recessed design in paperboard, often used for logo placement.

Deinking

The removal of ink from paper during recycling to create clean pulp.

EDS

Energy Dispersive X-ray Spectroscopy.

EVA glue

Ethylene-Vinyl Acetate is an adhesive used in paper tapes.

Greyboard

A high-density board with good stiffness and strength. Without fluting it's thickness is more dimensionally stable compared to corrugated. Its ideal as a cost-effective substrate for a wide-range of uses where heft and rigidity are needed. It can be made from 100% recycled fiber and is typically covered in a paper top sheet to provide a stable, finished appearance.

Hang tab

Part of packaging that allows it to be displayed on hooks or shelves.

Machine Direction (MD)

The direction that a material unwinds as it's being fed into a press, tunnel, or any other device.

Molded fiber

Shaped paper pulp, often made from recycled materials, used for trays and inserts.

Glossary of terms



MSDS

Material Safety Data Sheet, a document containing information on occupational safety and health.

OCC

Old Corrugated Cardboard / Container, a common recycled material used in packaging.

PDP

Primary Display Panel, the panel facing front on a store shelf.

PET

Polyethylene Terephthalate, a common plastic used for thermoformed trays and corner tapes in hardware packaging.

PP lamination

Polypropylene lamination, a plastic film applied to paper-based packaging.

Recyclability

The ability of a material to be disposed of in a municipal recycling system and be identified, properly sorted, and ultimately be reprocessed and reused.

RELF box

Roll End Lock Front, a type of folding carton with tuck-in tabs.

Repulpability

The ability of a material to break down into fibers during the paper recycling process.

Rigid box

A premium packaging structure, often used for electronics, typically made from greyboard.

Reliability testing

A suite of tests (vibration, drop, environmental conditioning and more) to simulate supply chain stresses.

Score / fold cracking

Damage at folded edges of paperboard.

Scuffing

Surface damage caused by abrasion.

SEM

Scanning Electron Microscopy.

Glossary of terms



Stickies

Small, tacky contaminants in recycled pulp that can disrupt papermaking equipment.

Stretchability

The ratio of measured elongation at the moment of rupture of test specimen, when extended under the conditions defined in the standard method of test (ISO 1924-2:2008).

Sustainability

The practice of design, engineering and operational activities to create positive environmental outcomes.

TDS

Technical Data Sheet, a document containing details on material properties.

Tensile energy absorption

The amount of energy a material can absorb before breaking.

Tensile strength

A material's resistance to breaking under tension.

Telescoping box

Two-piece rigid box where the lid slides over the base.

User experience

A user's journey of discovering, opening, and disposing of product packaging.

Visual appeal

The overall aesthetic of the packaging, including color, graphics, and finish.



Plastic-free materials library

Challenge

* * * * *

“Our material library reflects the deep collaboration and shared spirit of innovation that our suppliers have brought to our sustainable packaging solutions”

- Abhinav

Global Supply
Chain Manager



Materials

Main part category type	Sub part component/ category type	Supplier name	Grade name
Rigid Box	Top Sheet	HuaXia SunPaper	157gsm
Rigid Box	Greyboard	JinTian	1200gsm
Rigid Box		Sichuan Hongtu Scenery Environmental Technology Co., LTD	1050gsm
Rigid Box		Sen He Paper Co.,Ltd.	950gsm
Rigid Box	Paper Tape	BillerudKorsnäs (BK)	120gsm Brown
Various	UV Coating and inks	Megami	LH-GE Series (inks) LH-GE Matte OP (Coating)
Various	Kaili Glory Paper	Shandong Kaili Specialty Paper Co., LTD.	100, 160, 200 and 300gsm
Sleeve	Invercote G	Iggesund	240gsm
RELF Retail Box	Top Sheet	HuaXia SunPaper	250gsm
RELF Retail Box	Single Face Corrugate	Various	F-flute
Folding carton retail box	Paperboard	HuaXia SunPaper	300gsm
Folding carton retail box	Paperboard	HuaXia SunPaper	350gsm
Corrugated inserts	Top Sheet	HuaXia SunPaper	250gsm
Various	Water based glue	Guanli	MA-7601

Materials (continued)

Main part category type	Sub part component/ category type	Supplier name	Grade name
Corrugated inserts	Single Face Corrugate	Various	E-flute (100g Kraft/200g Kraft)
Corrugated inserts		Various	F-flute 175g #1 White (100g Kraft/200g Kraft)
Corrugated inserts		Various	G-flute (120 Kraft/180g white kraft)
Cable wraps, complex folding inserts	Paperboard inserts	HuaXia SunPaper	Starblanc C2S Bristol 250gsm
Cable wraps, complex folding inserts	Paperboard inserts		Starblanc C2S Bristol 300gsm
Cable wraps, complex folding inserts	Paperboard inserts		Starblanc C2S Bristol 350gsm

White molded fiber blend	Fiber composition	Thickness
White molded fiber	65% Bamboo pulp 35% Bagasse pulp	0.60mm- 1.20mm
White molded fiber (reinforced)	55% Bamboo pulp 35% Bagasse pulp 10% Wood pulp	1.0mm

Speckled molded fiber blend	Fiber composition	Thickness
Speckled molded fiber	66.5% Bamboo pulp 28.5% Bagasse pulp 5% Recycled newspaper	0.60mm- 1.50mm
Kraft molded fiber	100% Old Corrugated Containers	1.80-3.50mm

Materials (continued)

Protective wraps	Supplier name	Grade name
Documentation/translucent paper wraps	Arjowiggins	GT-63-HM
Box closure labels	UPM	
Screen protectors	Sun	128gsm ArtPaper
Screen protectors	Meixin	MXPR-0001AU
Product protection	Neenah	S5001

Pressure sensitive adhesives	Sub part component/ category type	Supplier name	Grade name
Various	Permanent adhesive	3M	9080A
Various	Permanent adhesive	3M	9988EG
Various	Differential adhesive	Meixin	MXPR-0017DAU
Various	Permanent adhesive	Crown	DS10A1
Various	Differential adhesive	Crown	DT742YH

Packaging converter supplier list

Name	Product(s) for Google	Company website
Cymmetrik	Labels, screen films.	https://www.cymmetrik.com
Intramedia	Printing bundle, molded fiber, boxes.	https://www.imedia.com.tw
Lihua/Hyperpack	Boxes, corrugated cartons, printed bundle assembly and molded fiber.	http://www.lihua-printing.com
MYS	boxes, corrugated cartons, high frequency welding in boxes.	https://www.szmys.com
Paishing	Boxes, corrugated cartons, printed bundle assembly, molded fiber.	http://www.paishing.com
YUTO	Boxes, corrugated cartons, printing bundle assembly.	https://www.szyuto.com

Acknowledgements

Our work on plastic-free packaging has been made possible by the talent, creativity, and dedication of many individuals from across Google and our suppliers.

Contributors to this include Google's packaging engineering, design, operations, and sustainability strategy teams.



Resources

1. [The world's plastic pollution crisis, explained.](#)
National Geographic, 2024
2. [Earth Day 2022.](#) Public Opinion on Climate Change.
3. Per [ISO 0472-2013.](#) Plastic, noun. Material which contains as an essential ingredient a high polymer and which, at some stage in its processing into finished products, can be shaped by flow.
4. Note 1 to entry: Elastomeric materials, which are also shaped by flow, are not considered to be plastics.

Google

Plastic-Free Packaging Design Guide

We'd love to hear about ways you've found this guide helpful, technical questions you have or suggestions to improve it.

Let us know at packaging_sustainability@google.com

Google is driving sustainability innovation in many different areas across our products and operations.

Check out the latest news and progress at:
sustainability.google